

GENERAL CATALOGUE

***HIGH
PRESSURE
PUMPS
H SERIES***



 **HPP**
HIGH PRESSURE PUMPS

TECHNICAL DETAILS



GENERAL NOTE: All specifications are not binding.
The Company reserves the right to change technical and aesthetics specifications without notice.

H SERIES

New series of high pressure pumps

HPP is a Comet SpA brand specialized in the design and construction of plunger pumps for water, made even better thanks to its technological expertise and further boosted by modern day technologies. This means the company is able to offer a wide range of products to meet requirements that go from 50 to 550 kW with pressures up to 2800 bar.



HPP pumps are manufactured using the most modern technologies both as regards to the materials used machining and mechanical operations and heat treatments. Comet is also able to provide a wide range of accessories, suitable for the specific needs of the single user. Professionalism and research make it a dynamic modern company intent on tackling and resolving the problems of a fast-evolving market.

INTELLI HEAD



IV GENERATION HEADS WITH INTELLIVALVE TECHNOLOGY

- New IV generation heads for SAP & UAP pumps
- System equipped with single-block valve mechanism
- Fewer components (-88%) than previous generation
- Less time (-83%) for maintenance operations
- Increased components lifetime
- Possibility to upgrade also for previous generation heads

INTELLIVALVE TECHNOLOGY

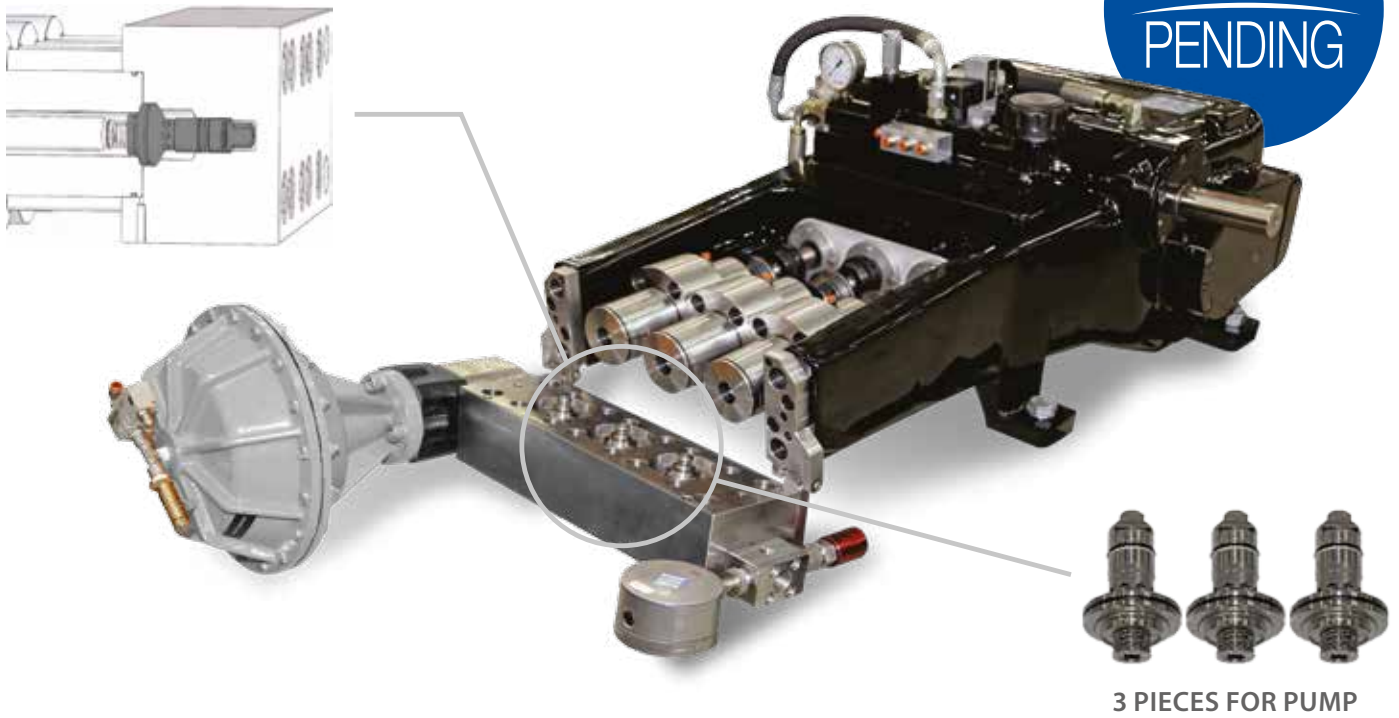

BENEFITS



Fewer pieces



Maximum pressure
40.000 psi
(2800 bar)



Longer useful life
of components



Flow rate up
to 38 USgpm
(145 l/min)



Easy to
assemble



Independent
operation



Quick and easy
maintenance in
15 minutes

PERFORMANCES

LEGEND

 With tungsten carbide plunger

 With forced lubrication

 Heat exchanger





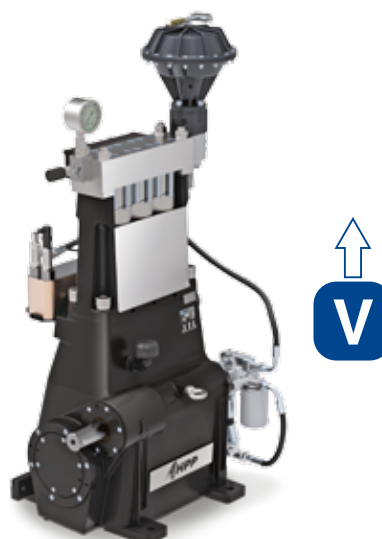

 **V** Vertical assembling

 **H** Horizontal assembling



SAP SERIES UP TO 1500 BAR

H-100 SAP  

 IV GENERATION		Motor Engine		Crankshaft									
Code	Ø mm	rpm	gear ratio	rpm	l/min	USgpm	bar	psi	MPa	HP	kW	kg	lb
P231152H14180	18	1500	2,9	517	31,6	8,3	1400	20300	140	111,3	81,9	400	882
P231162H14180		1800	3,6	502	30,6	8,1	1400	20300	140	107,9	79,4	400	882
P231152H14200	20	1500	2,9	517	39,0	10,3	1000	14500	100	98,1	72,2	400	882
P231162H14200		1800	3,6	502	37,8	10,0	1000	14500	100	95,2	70,0	400	882
P231152H14220	22	1500	2,9	517	47,2	12,5	900	13050	90	106,9	78,6	400	882
P231162H14220		1800	3,6	502	45,7	12,1	900	13050	90	103,6	76,2	400	882
P231152H14240	24	1500	2,9	517	56,1	14,8	750	10875	75	106,0	78,0	400	882
P231162H14240		1800	3,6	502	54,4	14,4	750	10875	75	102,8	75,6	400	882
P231152H14260	26	1500	2,9	517	65,9	17,4	650	9425	65	107,8	79,3	400	882
P231162H14260		1800	3,6	502	63,9	16,9	650	9425	65	104,5	76,9	400	882
P231152H14280	28	1500	2,9	517	76,4	20,2	600	8700	60	115,4	84,9	400	882
P231162H14280		1800	3,6	502	74,1	19,6	600	8700	60	111,9	82,3	400	882
P231152H14300	30	1500	2,9	517	87,7	23,2	500	7250	50	110,4	81,2	400	882
P231162H14300		1800	3,6	502	85,1	22,5	500	7250	50	107,1	78,8	400	882
P231152H14320	32	1500	2,9	517	99,8	26,4	420	6090	42	105,5	77,6	400	882
P231162H14320		1800	3,6	502	96,8	25,6	420	6090	42	102,3	75,3	400	882
P231152H14350	35	1500	2,9	517	119,4	31,5	330	4785	33	99,2	73,0	400	882
P231162H14350		1800	3,6	502	115,8	30,6	330	4785	33	96,2	70,7	400	882
P231152H14400	40	1500	2,9	517	155,9	41,2	270	3915	27	106,0	78,0	400	882
P231162H14400		1800	3,6	502	151,2	39,9	270	3915	27	102,8	75,6	400	882

Performances refer to theoretical delivery with 100% volumetric efficiency. For continuous or heavy-duty use, contact our technical department.

H-150 SAP

IV GENERATION	IV GENERATION		Motor Engine		Crankshaft									
Code	Code	Ø mm	rpm	gear ratio	rpm	l/min	USgpm	bar	psi	MPa	HP	kW	kg	lb
P231552V14220	P231552H14220	22	1500	2,9	517	47,2	12,5	1400	20300	140	166,3	122,3	400	882
P231562V14220	P231562H14220		1800	3,6	502	45,7	12,1	1400	20300	140	161,2	118,6	400	882
P231552V14240	P231552H14240	24	1500	2,9	517	56,1	14,8	1200	17400	120	169,6	124,7	400	882
P231562V14240	P231562H14240		1800	3,6	502	54,4	14,4	1200	17400	120	164,5	121,0	400	882
P231552V14260	P231552H14260	26	1500	2,9	517	65,9	17,4	1000	14500	100	165,9	122,0	400	882
P231562V14260	P231562H14260		1800	3,6	502	63,9	16,9	1000	14500	100	160,8	118,3	400	882
P231552V14280	P231552H14280	28	1500	2,9	517	76,4	20,2	830	12035	83	159,7	117,4	400	882
P231562V14280	P231562H14280		1800	3,6	502	74,1	19,6	830	12035	83	154,8	113,9	400	882
P231552V14300	P231552H14300	30	1500	2,9	517	87,7	23,2	750	10875	75	165,6	121,8	400	882
P231562V14300	P231562H14300		1800	3,6	502	85,1	22,5	750	10875	75	160,6	118,1	400	882
P231552V14320	P231552H14320	32	1500	2,9	517	99,8	26,4	640	9280	64	160,8	118,3	400	882
P231562V14320	P231562H14320		1800	3,6	502	96,8	25,6	640	9280	64	155,9	114,7	400	882
P231552V14350	P231552H14350	35	1500	2,9	517	119,4	31,5	560	8120	56	168,3	123,8	400	882
P231562V14350	P231562H14350		1800	3,6	502	115,8	30,6	560	8120	56	163,2	120,1	400	882
P231552V14400	P231552H14400	40	1500	2,9	517	155,9	41,2	400	5800	40	157,0	115,5	400	882
P231562V14400	P231562H14400		1800	3,6	502	151,2	39,9	400	5800	40	152,3	112,0	400	882

Performances refer to theoretical delivery with 100% volumetric efficiency. For continuous or heavy-duty use, contact our technical department.

H-200 SAP

IV GENERATION	IV GENERATION		Motor Engine		Crankshaft									
Code	Code	Ø mm	rpm	gear ratio	rpm	l/min	USgpm	bar	psi	MPa	HP	kW	kg	lb
P232052V14220	P232052H14220	22	1500	3,14	478	54,5	14,4	1470	21315	147	201,8	148,4	500	1103
P232062V14220	P232062H14220		1800	3,79	475	54,1	14,3	1470	21315	147	200,4	147,4	500	1103
P232052V14240	P232052H14240	24	1500	3,14	478	64,9	17,1	1300	18850	130	212,4	156,2	500	1103
P232062V14240	P232062H14240		1800	3,79	475	64,4	17,0	1300	18850	130	210,9	155,1	500	1103
P232052V14260	P232052H14260	26	1500	3,14	478	76,1	20,1	1200	17400	120	230,1	169,2	500	1103
P232062V14260	P232062H14260		1800	3,79	475	75,6	20,0	1200	17400	120	228,5	168,0	500	1103
P232052V14280	P232052H14280	28	1500	3,14	478	88,3	23,3	1000	14500	100	222,3	163,5	500	1103
P232062V14280	P232062H14280		1800	3,79	475	87,7	23,2	1000	14500	100	220,8	162,4	500	1103
P232052V14300	P232052H14300	30	1500	3,14	478	101,4	26,8	800	11600	80	204,2	150,2	500	1103
P232062V14300	P232062H14300		1800	3,79	475	100,7	26,6	800	11600	80	202,8	149,2	500	1103
P232052V14320	P232052H14320	32	1500	3,14	478	115,3	30,5	700	10150	70	203,3	149,5	500	1103
P232062V14320	P232062H14320		1800	3,79	475	114,5	30,3	700	10150	70	201,9	148,5	500	1103
P232052V14350	P232052H14350	35	1500	3,14	478	138,0	36,5	600	8700	60	208,5	153,3	500	1103
P232062V14350	P232062H14350		1800	3,79	475	137,0	36,2	600	8700	60	207,0	152,3	500	1103
P232052V14400	P232052H14400	40	1500	3,14	478	180,2	47,6	450	6525	45	204,2	150,2	500	1103
P232062V14400	P232062H14400		1800	3,79	475	179,0	47,3	450	6525	45	202,8	149,2	500	1103

Performances refer to theoretical delivery with 100% volumetric efficiency. For continuous or heavy-duty use, contact our technical department.

SAP & UAP PUMPS DIMENSIONS

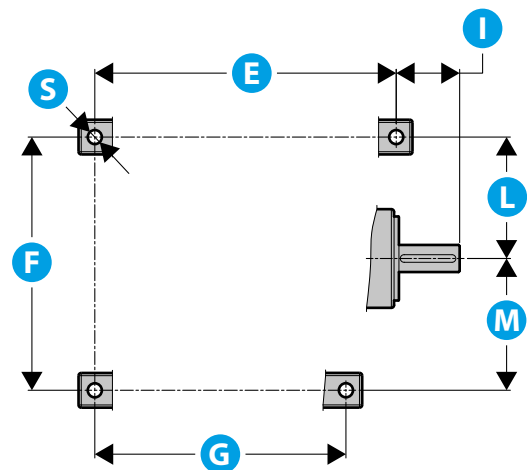
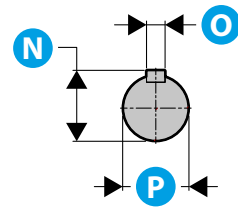
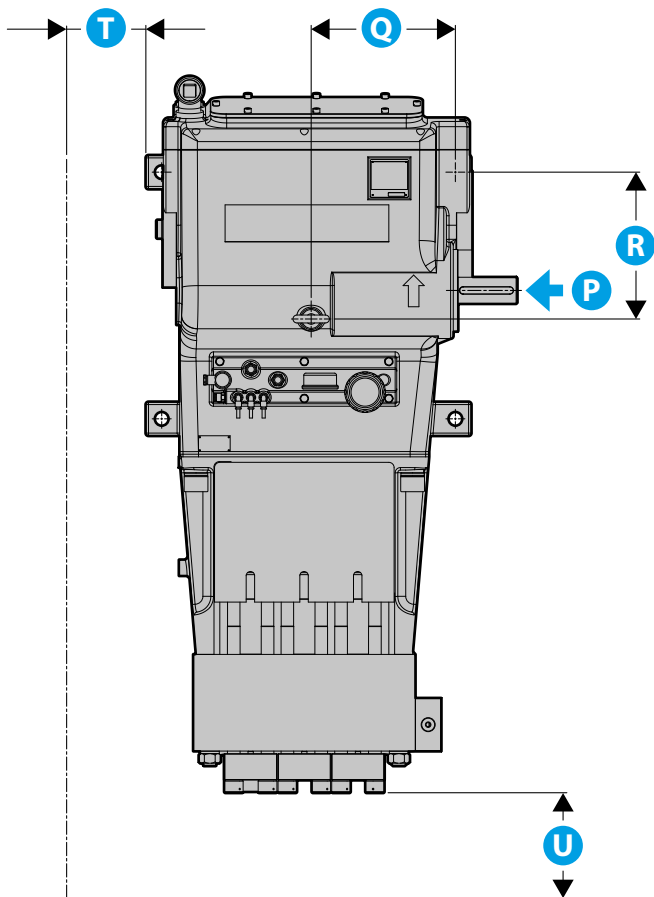
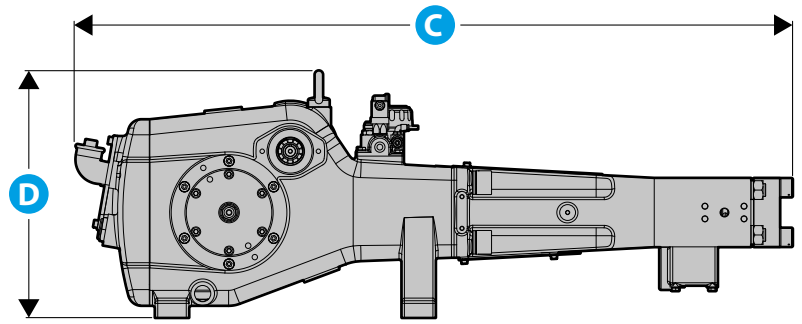
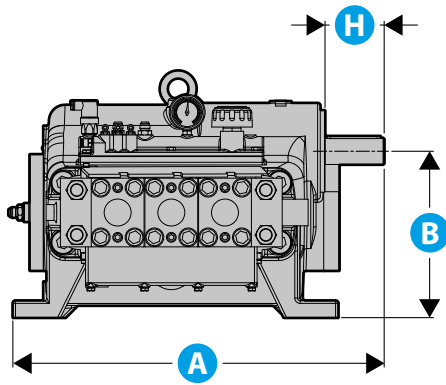

Pump Model		H-100 SAP	H-150 SAP	H-200 SAP	H-300 SAP	H-550 SAP	H-100 UAP	H-150 UAP	H-200 UAP	H-300 UAP
A	mm	699,5	699,5	703	739	1004	699,5	699,5	703	739
	(in)	(27,54)	(27,54)	(27,68)	(29,09)	(39,53)	(27,54)	(27,54)	(27,68)	(29,09)
B	mm	265	265	315	355	450	265	265	315	355
	(in)	(10,43)	(10,43)	(12,40)	(13,98)	(17,72)	(10,43)	(10,43)	(12,40)	(13,98)
C	mm	1121	1121	1220	1374	1528	1224	1224	1357	1416
	(in)	(44,13)	(44,13)	(48,03)	(54,09)	(60,16)	(48,19)	(48,19)	(53,43)	(55,75)
D	mm	407,5	407,5	467,5	505	699	407,5	407,5	467,5	505
	(in)	(16,04)	(16,04)	(18,41)	(19,88)	(27,52)	(16,04)	(16,04)	(18,41)	(19,88)
E	mm	565	565	556	592	813	565	565	556	592
	(in)	(22,24)	(22,24)	(21,89)	(23,31)	(32,01)	(22,24)	(22,24)	(21,89)	(23,31)
F	mm	390	390	467	540	610	390	390	467	540
	(in)	(15,35)	(15,35)	(18,39)	(21,26)	(24,02)	(15,35)	(15,35)	(18,39)	(21,26)
G	mm	546	546	556	592	720	545	545	556	592
	(in)	(21,50)	(21,50)	(21,89)	(23,31)	(28,35)	(21,46)	(21,46)	(21,89)	(23,31)
H	mm	120,5	120,5	112	126,5	182	120,5	120,5	112	126,5
	(in)	(4,74)	(4,74)	(4,41)	(4,98)	(7,17)	(4,74)	(4,74)	(4,41)	(4,98)
I	mm	110	110	117	117	158,5	109,5	109,5	117	117
	(in)	(4,33)	(4,33)	(4,61)	(4,61)	(6,24)	(4,31)	(4,31)	(4,61)	(4,61)
L	mm	190	190	224	286,4	343,5	190	190	224	286,4
	(in)	(7,48)	(7,48)	(8,82)	(11,28)	(13,5)	(7,48)	(7,48)	(8,82)	(11,28)
M	mm	200	200	243	253,6	266,5	200	200	243	253,6
	(in)	(7,87)	(7,87)	(9,57)	(9,98)	(10,49)	(7,87)	(7,87)	(9,57)	(9,98)
N	mm	43	43	53,5	62	79,5	43	43	53,5	62
	(in)	(1,69)	(1,69)	(2,11)	(2,44)	(3,13)	(1,69)	(1,69)	(2,11)	(2,44)
O	mm	12 (DIN 6885)	12 (DIN 6885)	14 (DIN 6885)	16 (DIN 6885)	20 (DIN 6885)	12 (DIN 6885)	12 (DIN 6885)	14 (DIN 6885)	16 (DIN 6885)
	(in)	(0,47)	(0,47)	(0,55)	(0,63)	(0,79)	(0,47)	(0,47)	(0,55)	(0,63)
P	mm	ø 40 +0,018 +0,002	ø 40 +0,018 +0,002	ø 50 +0,018 +0,002	ø 58 +0,021 +0,002	ø 75 +0,021 +0,002	ø 40 +0,018 +0,002	ø 40 +0,018 +0,002	ø 50 +0,018 +0,002	ø 58 +0,021 +0,002
	(in)	(ø 1,57)	(ø 1,57)	(ø 1,97)	(ø 2,28)	(ø 2,95)	(ø 1,57)	(ø 1,57)	(ø 1,97)	(ø 2,28)
Q	mm	272,5	272,5	273	320	401,5	272,5	272,5	273	320
	(in)	(10,73)	(10,73)	(10,75)	(12,60)	(15,79)	(10,73)	(10,73)	(10,75)	(12,60)
R	mm	231	231	278	340	426	231	231	278	340
	(in)	(9,09)	(9,09)	(10,94)	(13,39)	(16,77)	(9,09)	(9,09)	(10,94)	(13,39)
S	mm	ø 26	ø 26	ø 26	ø 26	ø 28	ø 26	ø 26	ø 26	ø 26
	(in)	(ø 1,02)	(ø 1,02)	(ø 1,02)	(ø 1,02)	(1,10)	(ø 1,02)	(ø 1,02)	(ø 1,02)	(ø 1,02)
T	mm	150	150	150	150	150	150	150	150	150
	(in)	(5,91)	(5,91)	(5,91)	(5,91)	(5,91)	(5,91)	(5,91)	(5,91)	(5,91)
U	mm	500	500	500	500	500	500	500	500	500
	(in)	(19,69)	(19,69)	(19,69)	(19,69)	(19,69)	(19,69)	(19,69)	(19,69)	(19,69)